

BEFCO[®]

Operator's Manual

QUICK HITCH ADAPTER

fits Cyclone C30-RD4, C30-RD5 & C30-RD6

001-700

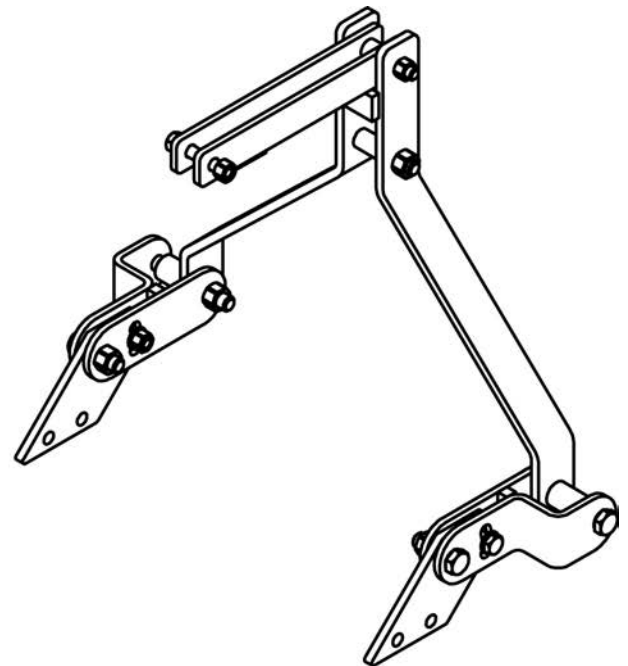
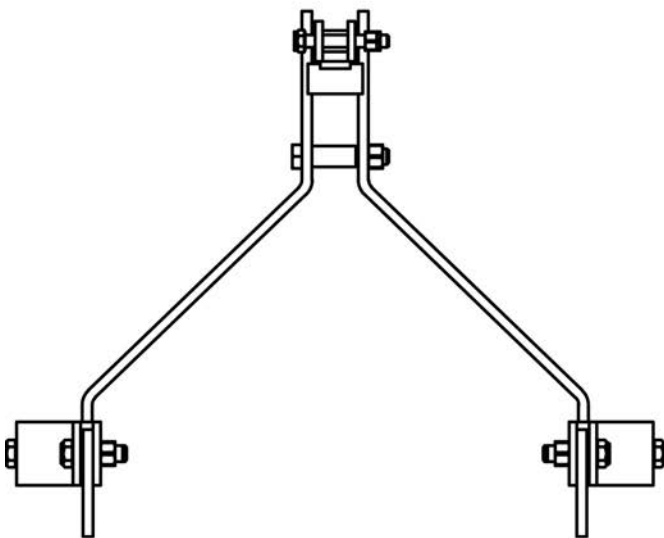

The operator's manual is a technical service guide and must always accompany the machine.

Manual 971-213B

May 2023

SAFETY

Take note! This safety alert symbol found throughout this manual is used to call your attention to instructions involving your personal safety and the safety of others. Failure to follow these instructions can result in injury or death.



*This symbol means:
ATTENTION!
BECOME ALERT!
YOUR SAFETY IS INVOLVED!*

Signal Words

Note the use of the signal words DANGER, WARNING and CAUTION with the safety messages. The appropriate signal words for each have been selected using the following guidelines:



DANGER: Indicates an imminently hazardous situation that, if not avoided, will result in death or serious injury.



WARNING: Indicates a potentially hazardous situation that, if not avoided, could result in death or serious injury, and includes hazards that are exposed when guards are removed. It may also be used to alert against unsafe practices.



CAUTION: Indicates a potentially hazardous situation that, if not avoided, may result in minor or moderate injury.

INDEX

1 - GENERAL INFORMATION	4
1.01 - General	4
1.02 - Quick Hitch Adapter Assembly and Operation	4
2 - SAFETY PRECAUTIONS	7
2.01 - Preparation	7
2.02 - Starting and Stopping	8
2.03 - Messages and Signs	8
PARTS MANUAL	9

1 - GENERAL INFORMATION

Thank you and congratulations for having chosen this accessory. It is technologically advanced and constructed of high quality, sturdy components that will fulfill your working expectations. Read this manual carefully. It will instruct you on how to operate and service your implement safely and correctly. Failure to do so could result in personal injury and/or in equipment damage.

1.01 - General



CAUTION: Unless otherwise specified, all hardware is metric. Use only metric tools on metric hardware. Other tools that do not fit properly can slip and cause injury.

1.02 - Quick Hitch Adapter Assembly and Operation

Using a Quick Hitch system:

The C30 series mowers can be used with a Quick Hitch system, allowing for quick and easy hookup, by installing an optional adapter. This optional adapter has floating yokes that will allow the mower to follow the contour of the ground.

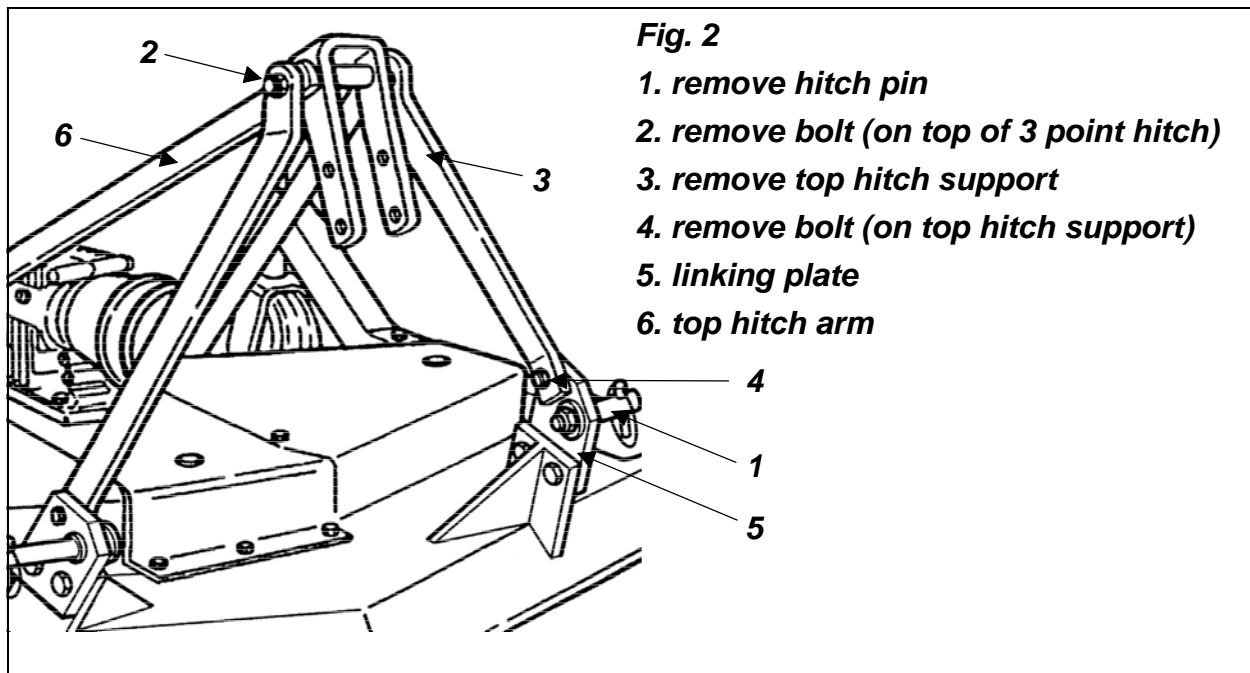



WARNING: When using a Quick Hitch on a PTO driven implement always ensure there is the proper driveline overlap prior to use. If there is not the minimum 6" driveline overlap do not use and contact your nearest dealer to purchase a longer driveline.

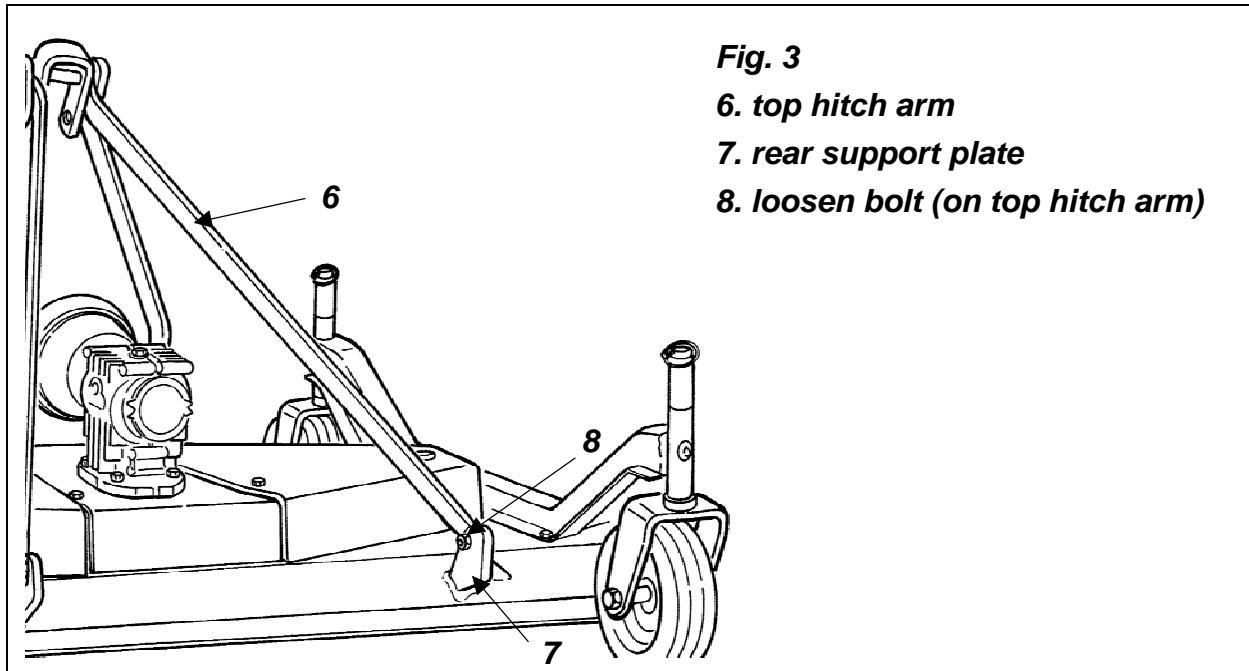

Quick Hitch Adapter assembly:

1. Remove hitch pins (see #1, fig. 2) from grooming mower's linking plates (see #5, fig. 2).
2. Remove M16x140 bolt (see #2, fig. 2) on top of the three point hitch of the grooming mower.
3. Remove M20x45 bolts (see #4, fig. 2) that hold the top hitch supports (see #3, fig. 2) to the linking plates of the mower.
4. Attach the floating yokes of quick hitch adapter assembly (see fig. 4) to the linking plates of the mower. Note: Two 1/2" long bushings for the floating yokes are provided in the hardware bag of the quick hitch adapter kit. Ensure these bushings are installed onto the M16x60 bolt.
5. Attach the floating top link (see fig. 4) to the top hitch arms (see #6, fig. 2) using the M16x90 bolt and nut.
6. Attach the A-frame support (see fig. 4) to the floating top link using the M16x110 bolt and nut.
7. Install the M20x110 bolt with the 1-1/8" spacer into the A-frame support.
8. Insert the M20x140 bolt into the floating yokes. The order should be as follows: bolt, first half of floating yoke, 1-3/8" spacer, A-frame support, M20 jam nut, second half of floating yoke, M20 nut. The two M20 nuts need to be jammed against each side of the floating yokes of the mower. This will allow some motion in the spacer.

9. Loosen the M16x40 bolts (see #8, fig. 3) that secure the top hitch arms (see #6, fig. 2 & 3) to the rear support plates (see #7, fig. 3) of the mower. Only loosen slightly. The arms must be able to move slightly up and down.
10. Tighten all hardware, ensuring all bolts and nuts have enough play to allow quick hitch adapter to move up and down.

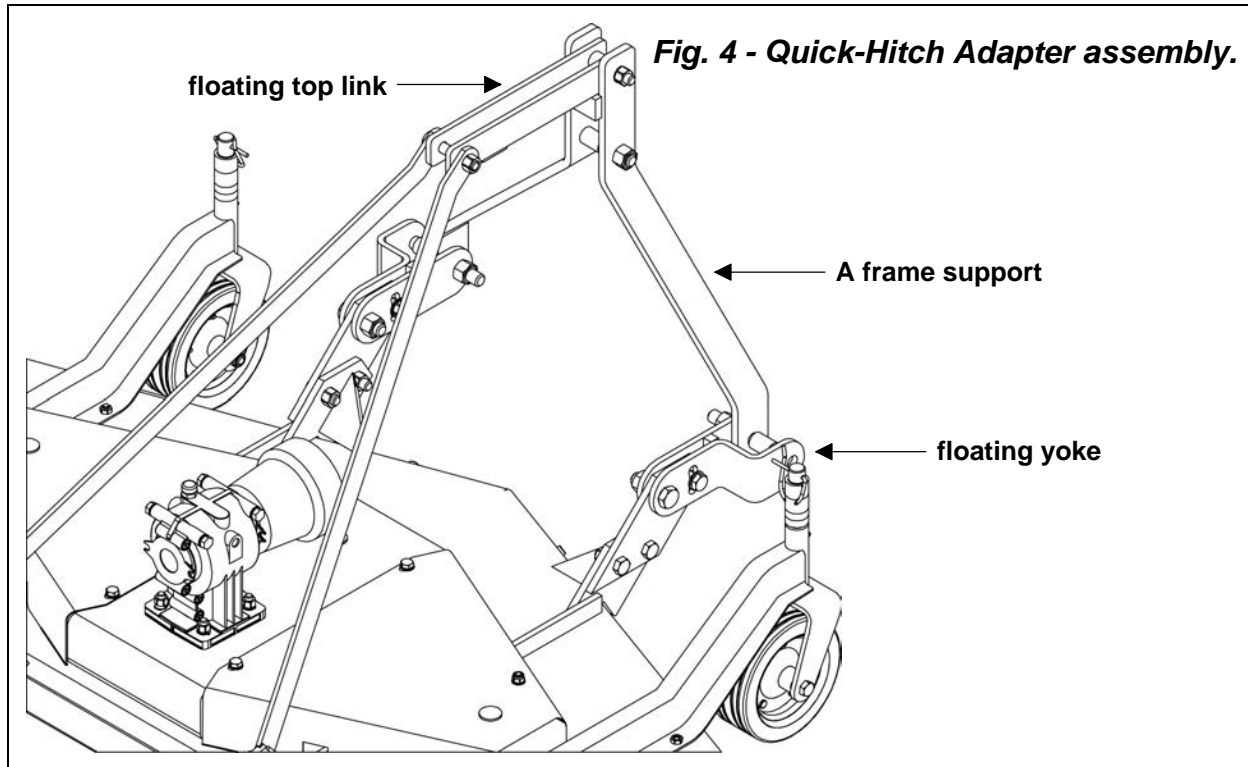

Quick Hitch adapter operation:

After completing assembly of the adapter, the tractor lift arms should be raised and locked in a position so the floating yokes are horizontal. Ensure that the M16x60 bolt is approximately in the center of the slot on the floating yoke. Positioning the bolt in this location allows the mower to have maximum float both up and down.



CAUTION: Improper setup of the quick hitch adapter can result in equipment damage. A replacement driveline must generally be installed to prevent injury or equipment damage when using the quick hitch adapter.



CAUTION: If the three point hitch of the tractor is set in the lowest position, the driveline may bottom out against the quick hitch resulting in a bent driveline. If the mower is lifted after the driveline has been bent, it may also damage the gearbox, mounting plates, and other hardware.

2 - SAFETY PRECAUTIONS

Safety is the primary concern in the design and manufacture of our products. Unfortunately our efforts to provide safe equipment can be wiped out by a single careless act of an operator.

In addition to the design and configuration of equipment, hazard control and accident prevention are dependent upon the awareness, concern, prudence and proper training of personnel involved in the operation, transport, maintenance and storage of equipment. It is the operator's responsibility to read and understand all safety and operating instructions in the manual and to follow these.

Allow only properly trained personnel to operate the mower. Working with unfamiliar equipment can lead to careless injuries. Read this manual, and the manual for your tractor, before assembly or operation, to acquaint yourself with the machines. It is the mower owner's responsibility, if this machine is used by any person other than yourself, is loaned or rented, to make certain that the operator, prior to operating, reads and understands the operator's manuals and is instructed in safe and proper use.

2.01 - Preparation



1. Before operating equipment read and understand the operator's manual and the safety signs (**see mower operator's manual**).
2. Thoroughly inspect the implement before initial operation to assure that all packaging materials, i.e. wires, bands, and tape have been removed.
3. Personal protection equipment including hard hat, safety glasses, safety shoes, and gloves are recommended during assembly, installation, operation, adjustment, maintaining and/or repairing the implement.
4. Operate the mower only with a tractor equipped with an approved Roll-Over-Protective-System (ROPS). Always wear your seat belt. Serious injury or even death could result from falling off the tractor.
5. Clear area to be cut of stones, branches or other debris that might be thrown, causing injury or damage.
6. Operate only in daylight or good artificial light.
7. Ensure mower is properly mounted, adjusted and in good operating condition.
8. Ensure that all safety shielding and safety signs are properly installed and in good condition.

2.02 - Starting and Stopping



1. Be sure that no one is near the machine prior to engaging or while the machine is working.
2. Be sure the tractor is in "Neutral" before starting engine.
3. Mower operating power is supplied from tractor PTO. Refer to your tractor manual for PTO engagement and disengagement instructions. Always operate PTO at 540 rpm. Know how to stop the tractor and mower quickly in case of an emergency.
4. When engaging PTO, the engine rpm should always be low. Once engaged and ready to start cutting, raise PTO speed to 540 rpm and maintain throughout cutting operation.
5. Check the tractor master shield over the PTO stub shaft. Make sure it is in good condition and fastened securely to the tractor. Purchase a new shield if old shield is damaged or missing.
6. After striking an obstacle, disengage the PTO, shut the tractor down and thoroughly inspect for damage before restarting.
7. Never engage the PTO until the mower is in the down position and resting on the ground. Never raise the mower until all blades have come to a complete stop.
8. To park the vehicle safely, stop vehicle on a level surface (not on a slope), disengage PTO, engage the parking brake, stop the engine, remove the key, and wait for engine and all moving parts to stop before leaving the operator's seat.
9. Stay clear of rotating drivelines. Entanglement in rotating driveline can cause serious injury or death. Wear close fitting clothing. Stop the engine and be sure PTO driveline is stopped before getting near it.

2.03 - Messages and Signs



1. Read and adhere to all safety and operating decals on this machine (**see mower operator's manual**).
2. Before dismounting tractor: allow moving parts to stop, stop engine, set brake and remove the key of unattended equipment.
3. Keep away from rotating blades and driveline.
4. Keep guards and shields in place and in good condition.
5. Do not mow with bystanders in area.
6. Allow no riders on tractor or mower.
7. Allow moving parts to stop before repair.
8. Securely support mower before working underneath.

Additional warning and operating decals are available at no extra charge. Please specify model and serial number when ordering.

BEFCO®

Parts Manual

QUICK HITCH ADAPTER

fits Cyclone C30-RD4, C30-RD5 & C30-RD6

001-700

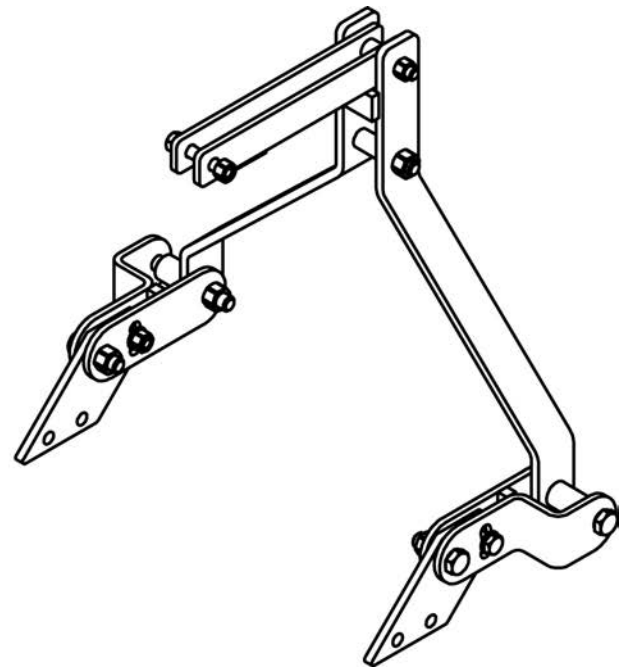
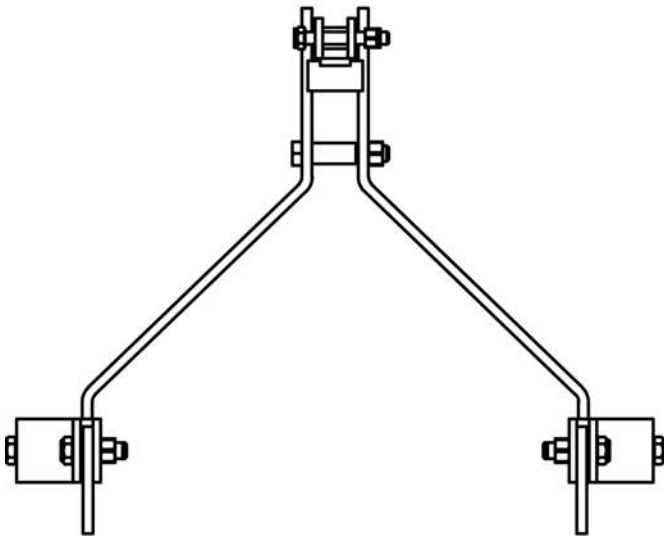

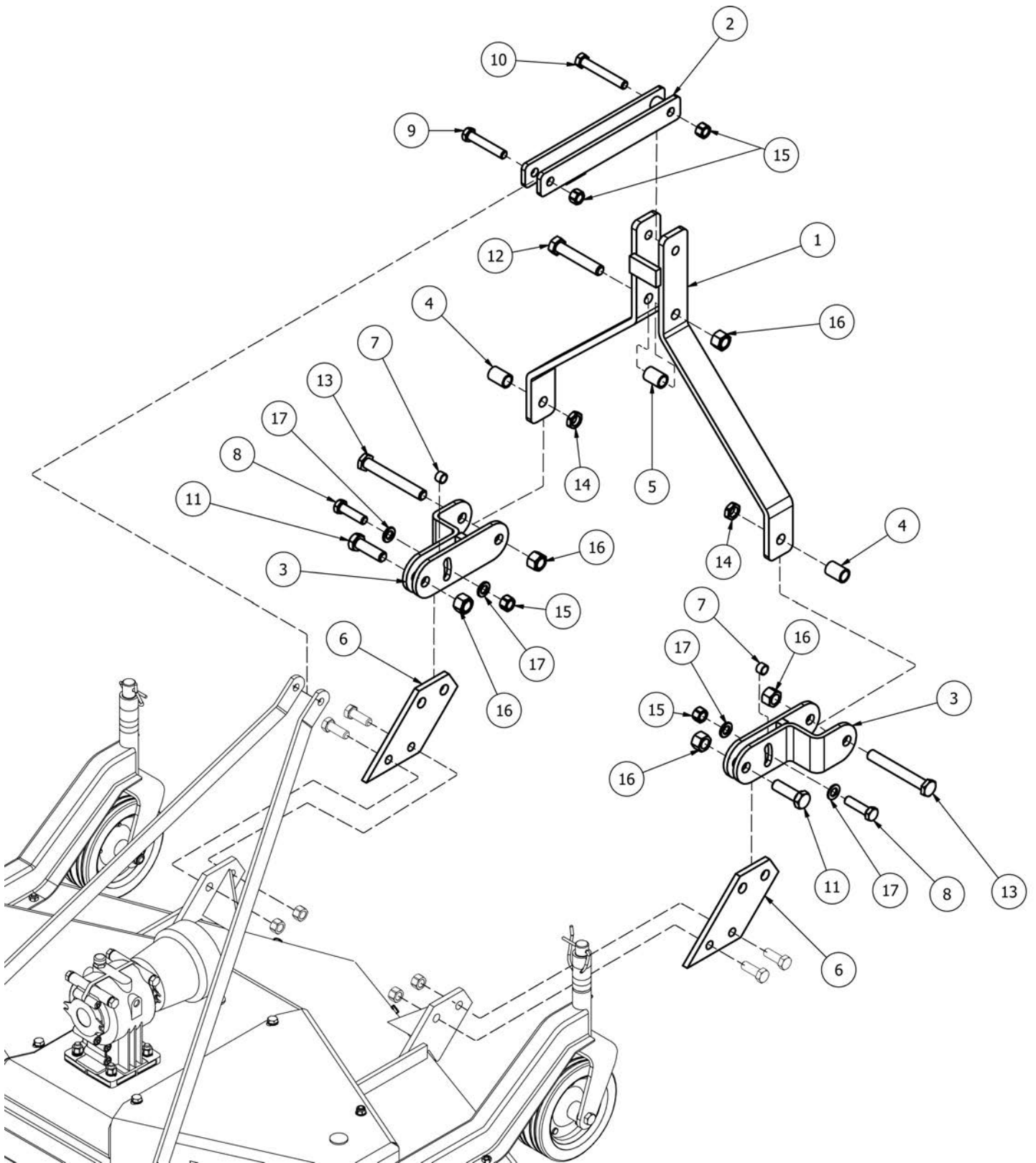

Ref.	Part #	Description	Qty.
1	503-753B	A frame support	1
2	503-754B	Floating top link	1
3	005-1941	Floating yoke	2
4	503-755B	Spacer 1-3/8"	2
5	503-756B	Spacer 1-1/8"	1
6	005-1817	Linking plate	2
7	503-757B	Bushing	2
8	000-6577	Bolt HH M16-2.00x60 C8.8 Z P	2
9	000-8029	Bolt HH M16-2.00x90 C8.8 Z P	1
10	007-0346	Bolt HH M16-2.00x110 C8.8 Z P	1
11	000-8576	Bolt HH M20-2.50x65 C8.8 Z F	2
12	005-1953	Bolt HH M20-2.50x110 C8.8 Z P	1
13	005-1954	Bolt HH M20-2.50x140 C8.8 Z P	2
14	001-5686	Nut HH M20-2.50 C6 Z TN	2
15	000-5581	Nut PT M16-2.00 C6 Z TK	4
16	000-5507	Nut PT M20-2.50 C6 TK Z	5
17	000-8568	Washer flat Ø16 W	4
	001-700	Quick-Hitch Adapter complete (field conversion kit)	1
	971-213B	Operator's and parts manual, quick-hitch adapter	1

BEFCO[®]

P.O. Box 6036
Rocky Mount, NC 27802-6036
Tel.: 252.977.9920 - Fax: 252.977.9718
www.befco.com

